

Lexmark CS796de colour laser printer



Flexible, robust colour.



Colour



Touch
Screen



Solutions



Up to
50 ppm



Duplex



Network

LEXMARK
TM

Lexmark CS796de ordering information

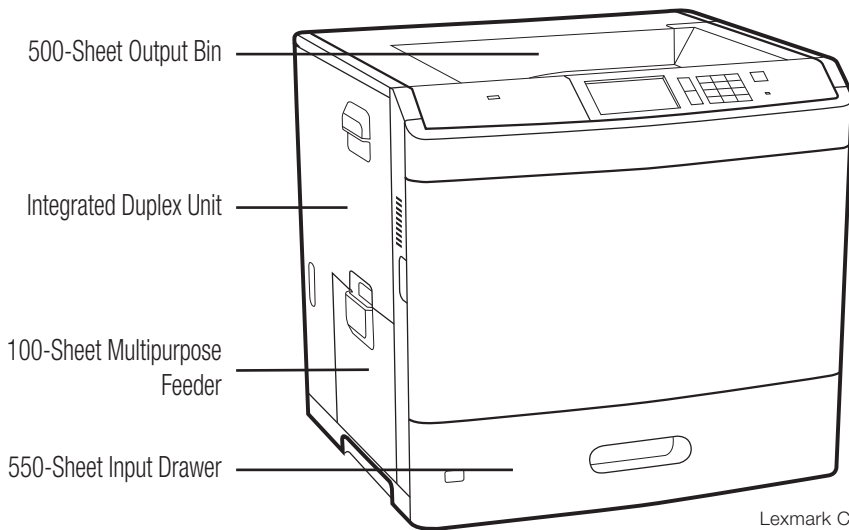

Lexmark CS796de shown
Part #47B0005

500-Sheet
Offset Stacker

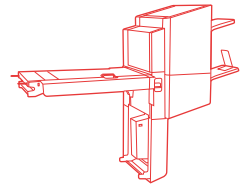

or

500-Sheet
Stapler Finisher

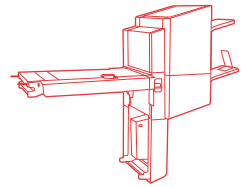

or

5-Bin Mailbox

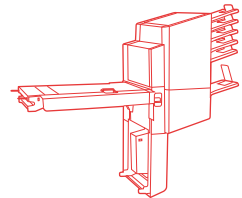

or

500-Sheet Staple
Punch Finisher

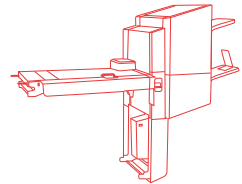

550-Sheet
Input Drawers

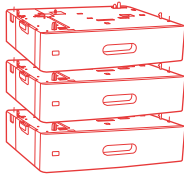

or

550-Sheet
Input Drawer
2,000-Sheet High
Capacity Feeder

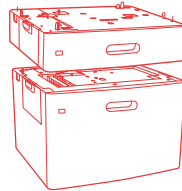

Spacers

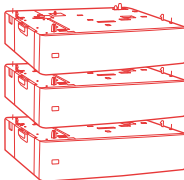

or

Caster Base
(Required for
floor standing
configuration)

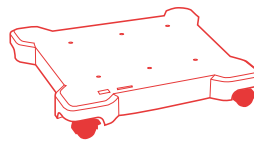

Standard

Optional

Compatible on the CS796de colour laser printer

Part # Laser Toner/Print Cartridge

24B4495	CS796 Black Extra High Yield Return Program Print Cartridge
24B4492	CS796 Magenta Extra High Yield Return Program Print Cartridge
24B4491	CS796 Cyan Extra High Yield Return Program Print Cartridge
24B4493	CS796 Yellow Extra High Yield Return Program Print Cartridge

Part # Memory Options

1025041	256MB DDR2-DRAM
1025042	512MB DDR2-DRAM
1025043	1024MB DDR2-DRAM
14F0245	256MB Flash Card
27X0014	160+GB Hard Disk

Part # Application Solutions

47B1114	Card for IPDS
47B1113	Forms and Bar Code Card
47B1115	Card for PRESCRIBE Emulation

Part # Connectivity

27X0025	MarkNet N8250 802.11b/g/n Wireless Print Server
14F0037	MarkNet N8120 Gigabit Ethernet Print Server
14F0042	MarkNet N8130 Fiber Ethernet 100BaseFX, 10BaseFL Print Server
14T0220	MarkNet™ N7020e Gigabit Ethernet Print Server
1021294	USB Cable (2-meter)
14F0000	Parallel 1284-B Interface Card
1021231	Parallel Cable (10-foot)
14F0100	RS-232C Serial Interface Card

Part # Paper Handling

47B0110	550-Sheet Input Drawer
47B0111	2,000-Sheet High Capacity Feeder
47B0112	Spacer
47B0114	Caster Base
47B1100	500-Sheet Stapler Finisher
47B1101	5-Bin Mailbox
47B1102	500-Sheet Offset Stacker
47B1103	500-Sheet Staple Punch Finisher

Lexmark CS796de key features

Features that help you optimize your work



Lexmark CS796de colour laser printer shown with optional input drawers, finisher and caster base



1) Intuitive colour touch screen

The 4.3-inch colour touch screen allows you to operate your printer with ease and confidence through smart and intuitive navigation, easy access to workflow solutions and shortcuts, and the ability to preview your documents and print jobs at the device.



2) Flexible output options

Choose from four output options, including a five-bin mailbox, an offset stacker, a staple finisher, and a staple with hole punch finisher.



3) Direct USB

A front USB port allows for convenient walk-up preview and printing and is compatible with most printable image file formats.



4) Lexmark solutions

Reduce unnecessary printing and simplify work processes through solutions applications preloaded on your device. Choose additional Lexmark solutions to fit your unique workflow needs.



5) Expandable input

Print on multiple paper types and boost total capacity up to 3,200 sheets.



6) Long-lasting toner

The Lexmark Extra High Yield Print Cartridge delivers up to 20,000* pages, reducing interventions, cartridge waste and cost.



7) Eco-friendly features

Easy-to-access features make it easy to print responsibly, including Eco-Mode to reduce paper and toner consumption, and the Sleep Button to help you save energy.

*Average continuous black or composite CMY declared cartridge yield in accordance with ISO/IEC 19798.



Lexmark CS796de colour



Lexmark colour. Enhance comprehension and brand credibility with colour that helps your customers believe in—and remember—your products and services.

The Lexmark CS796de is perfect for printing reports, colour spreadsheets and on-demand signage with brilliant colour reproduction.

So when you put a high-quality colour document in a client's hands, you're advancing communication and your company's image at the same time. With Lexmark colour laser printing, the professionalism of your documents can finally match that of your company.



Lexmark's standard security features for your network, data and devices.

Output security has never been more important to businesses of all sizes. Lexmark's security functions include device management, device hardening and device operation. Strong multilayered security is built-in.

Device management tools include administrative access and passwords, HTTPS, SNMPv3, IP security (IPSec) and 802.1x support to remotely monitor and manage device usage.

Device hardening includes port filtering, TCP connection filtering, hard drive encryption, hard disk wiping, and digitally signed firmware updates which enhances the security of the device's network interface.

Device operation utilizes user authentication, address book lookup via LDAP over SSL and device lockout for protection of user information.

Lexmark has shown its strength and leadership with respect to security by:

- Forming and chairing the group that created the IEEE 2600 standards for security on hardcopy devices.
- Becoming the first hardcopy device manufacturer to take a holistic approach with the National Information Assurance Partnership (NIAP) Common Criteria evaluation.

Save time and money through solutions

Reduce unnecessary printing and simplify work processes through Lexmark solutions. The CS796de features the Lexmark Embedded Solutions Framework (eSF), our platform that enables you to add a wide range of software applications directly onto the device. Solutions are designed with your productivity in mind, helping you streamline—or even eliminate—paper intensive business processes.

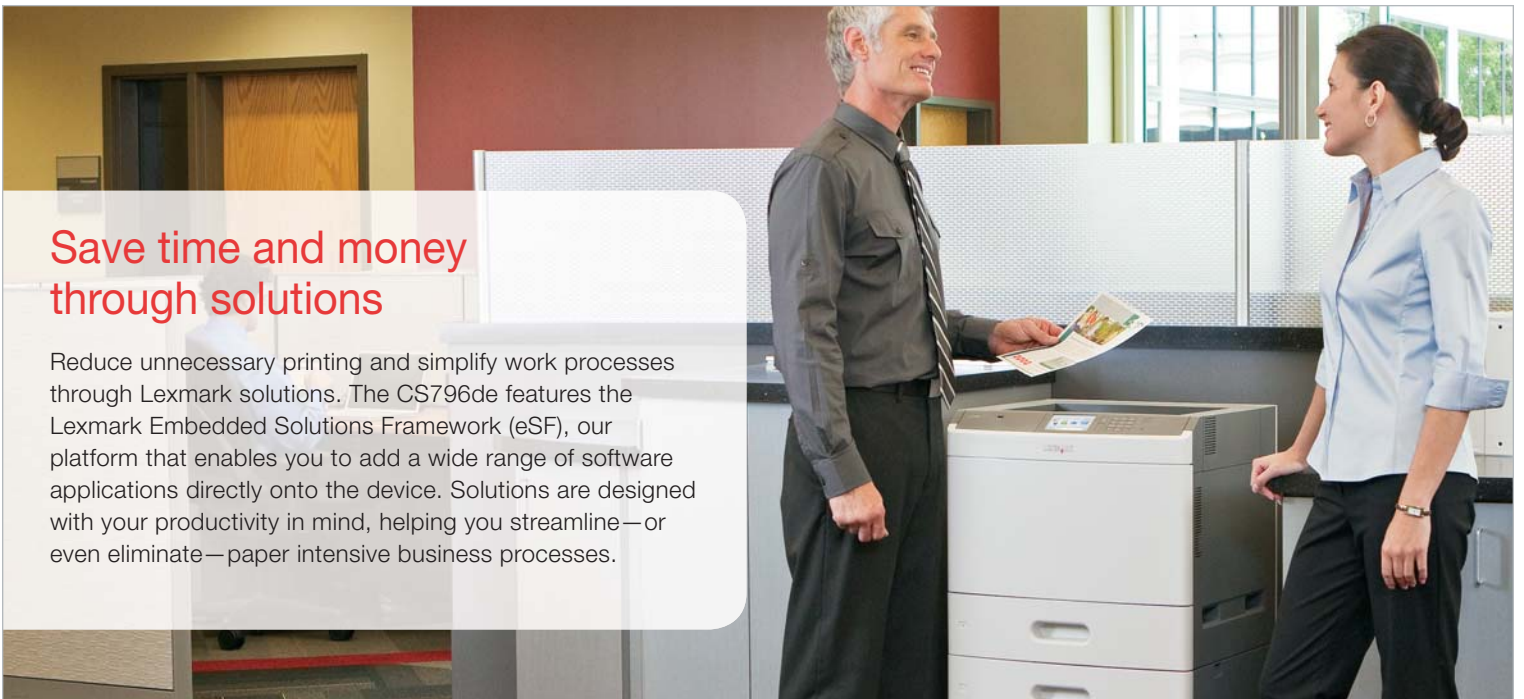

Lexmark CS796de solutions

The right touch. The Lexmark e-Task colour touch screen is a key access point to your device. The customizable 4.3-inch interface gives you the ability to preview thumbnails of documents prior to printing, as well as change print jobs at the device. You can even view, select and print specific pages within a document directly from the touch screen. Its easy-to-use, intuitive navigation provides fast access to the functions and shortcuts.



The following are solutions that come preloaded on the CS796de:



Showroom

Display a customizable, scrolling slideshow on the colour touch screen to promote your business or products, or to communicate important messages to your customers or employees.



Eco-Settings

Choose from multiple print settings to help reduce energy, paper and toner consumption.



Background and Idle Screen

Change the touch screen background to your corporate logo, custom images, a unique message or select from preloaded screens.



Forms and Favorites

Eliminate waste and inefficiencies associated with preprinted forms. Store frequently printed forms, marketing materials or other documents online, then print them on demand.



Lexmark CS796de overview



Robust Colour Output. Designed for medium to large workgroups, the Lexmark CS796de meets the demands of your busy colour-printing environment. Vibrant, professional-quality output and the ability to print on a wide variety of media allow you to do more colour printing in-house. With the advanced colour laser technology of the CS796de you'll get excellent, consistent colour from the first page to the last.

- Lexmark Extra High Yield Print Cartridge available, offering yields of up to 20,000* pages
- Print speeds as fast as 50 ppm in both black and colour
- PANTONE® calibration for consistent colour tones
- Named Colour Replacement for easy colour matching
- Lexmark Colour Care Technology to manage colour usage and control costs
- Instant warm-up fuser to help reduce energy consumption and improve time to first page



Flexibility. Choose from a variety of models to best serve your needs. Select from a number of expandability options and finishing features you would expect from more expensive products.

- Ultra-reliable paper feeding to support diverse media, including card stock, labels, UV-resistant outdoor media, banner media and more
- Robust output options, including a five-bin user-assignable mailbox, an offset stacker, a staple finisher, and a staple with hole punch finisher
- Input capacity expandable to up to 3,200 sheets with the high-capacity feeder and an extra drawer
- Connectivity and application solution cards allow integration into most IT environments



Easy and Intuitive. The Lexmark CS796de is designed for easy operation and maintenance.

- 4.3-inch colour touch screen provides audible feedback to make completing tasks intuitive
- Print preview features help you select documents or specific pages within a document
- Directional lights on the device provide visual cues to guide you through tasks
- Ability to change settings such as duplex or stapling at the device
- Available device fleet management software
- Sleep Button and Hibernate Mode to reduce energy costs

*Average continuous black or composite CMY declared cartridge yield in accordance with ISO/IEC 19798.



Why Lexmark?

Founded from an IBM heritage in Lexington, Kentucky, in 1991, Lexmark is one of the few American companies to own, develop and market inkjet, laser and colour laser print technologies. Lexmark is poised to deliver on its promise to produce quality, dependable products well into the future.

Lexmark CS796de highlights



Make a lasting impression with award-winning colour.

The documents you print define an important image – yours. That's why Lexmark colour lasers help businesses be more productive and stand out with vibrant colour. With the ability to print professional quality colour in-house, you can add instant impact and save costs by virtually eliminating the need to outsource print jobs. Lexmark also offers a host of colour-access and control tools to manage cost.



Eco-responsible. Printing responsibly means everyone wins – your business, your budget and the environment. Lexmark's award-winning products are designed for ease of use, high quality output and reliable performance, with innovative capabilities that help you minimize the number of cartridges you use over the life of the printer and conserve paper and energy. Our goal is to design, package and deliver innovative products and solutions in an environmentally responsible manner.

The Lexmark Cartridge Collection Program is active around the world providing a variety of methods for free returns of your empties to Lexmark or our collection partners. Our goal: Make it easy to do the right thing.



Environmental protection is a shared responsibility.

Through our work with industry groups, Lexmark helps guide the formation of standards and guiding principles for environmental sustainability.

Our memberships include:

- AeA Europe
- American National Standards Institute (ANSI)
- Ecma International
- Electronics Industry Citizenship Coalition (EICC)
- European Information & Communications Technology Industry Association (EICTA)
- Information Technology Industry Council (ITI)
- ITI Environmental Leadership Council

Lexmark CS796de product specifications



Lexmark CS796de
part # 47B0005

Speeds	
Black and Colour	Print up to 50 ppm Letter
Paper Handling	
Paper Capacity	Standard Input: 650; Standard Output: 500 Maximum Input: 3,200 (2,000 + 550 + 550 + 100); Maximum Output: 1,000
Media Information	Types: Card Stock, Dual Web Labels, Envelopes, Glossy Paper, Integrated Labels, Paper Labels, Plain Paper, Polyester Labels, Transparencies, Vinyl Labels, UV-Resistant Outdoor Media, Banner Media Size: Letter, Legal, Statement, Universal, Folio, Executive, A4, A5, JIS-B5, Envelopes (7-3/4, 9, 10, DL, B5, C5)
Print	
	Touch Screen: 4.3-inch Colour, Customizable Memory (Min/Max): 512 MB/1536 MB Time to First Page: As Fast as 8 Seconds (Black); As Fast as 8.5 Seconds (Colour) Resolution: 1200 x 1200 dpi; 4800 Colour Quality Processor: 1.2 GHz Connectivity (Standard): USB 2.0 Specification Hi-Speed Certified (Type B), Front USB 2.0 Specification Hi-Speed Certified Port (Type A), Rear USB 2.0 Specification Hi-Speed Certified Port (Type A), Ethernet 10/100/1000 BaseTX (RJ-45) Connectivity (Optional): Parallel, Serial, Wireless
Security	
	User authentication and authorization controls including LDAP; Card reader option to add an extra layer of security; Hard disk encryption protects sensitive data on the disk drive; Automatic scheduled or manual disk wiping; IPSec, SNMPv3 and 802.1x network security supported; Security-audit logging to help track and identify security risks
Supplies Yield	
	Ships with 11,000*-page Black Print Cartridge and 8,500*-Page (CMY) Print Cartridges; Aftermarket 20,000*-Page (CMYK) Extra High Yield Print Cartridges *Average continuous black or continuous composite CMY declared cartridge yield up to this number of standard pages in accordance with ISO/IEC 19798.
Recommended Monthly Volume	
	Up to 15,000 Pages/Month
Contact your dealer about workflow solutions.	

Recommended Monthly Page Volume

Recommended Monthly Page Volume is a range of pages that helps customers evaluate Lexmark's product offerings based on the average number of pages customers plan to print on the device each month. Lexmark recommends that the number of pages per month be within the stated range for optimum device performance, based on factors including: supplies replacement intervals, paper loading intervals, speed, and typical customer usage.

Trademarks

Lexmark and Lexmark with the diamond design are trademarks of Lexmark International, Inc., registered in the United States and/or other countries. All other trademarks are the property of their respective owners. PCL is a registered trademark of Hewlett-Packard Company. AppleTalk, Mac and Macintosh are trademarks of Apple Computer, Inc., registered in the United States and other countries. MarkNet and MarkVision are trademarks of Lexmark International, Inc., registered in the United States and/or other countries. ENERGY STAR® is a U.S. registered mark. Microsoft, Windows, the Windows logo, Windows Vista, and the Windows Vista logo are trademarks or registered trademarks of Microsoft Corporation in the United States and/or other countries. Citrix, MetaFrame and MetaFrame XP are registered trademarks or trademarks of Citrix Systems, Inc. in the U.S. and other countries. Information in this document is subject to change without notice.



Why Lexmark?

Founded from an IBM heritage in Lexington, Kentucky, in 1991, Lexmark is one of the few American companies to own, develop and market inkjet, laser and colour laser print technologies. Lexmark is poised to deliver on its promise to produce quality, dependable products well into the future.

Lexmark CS796de highlights



Make a lasting impression with award-winning colour.

The documents you print define an important image – yours. That's why Lexmark colour lasers help businesses be more productive and stand out with vibrant colour. With the ability to print professional quality colour in-house, you can add instant impact and save costs by virtually eliminating the need to outsource print jobs. Lexmark also offers a host of colour-access and control tools to manage cost.



Eco-responsible. Printing responsibly means everyone wins – your business, your budget and the environment. Lexmark's award-winning products are designed for ease of use, high quality output and reliable performance, with innovative capabilities that help you minimize the number of cartridges you use over the life of the printer and conserve paper and energy. Our goal is to design, package and deliver innovative products and solutions in an environmentally responsible manner.

The Lexmark Cartridge Collection Program is active around the world providing a variety of methods for free returns of your empties to Lexmark or our collection partners. Our goal: Make it easy to do the right thing.



Environmental protection is a shared responsibility.

Through our work with industry groups, Lexmark helps guide the formation of standards and guiding principles for environmental sustainability.

Our memberships include:

- AeA Europe
- American National Standards Institute (ANSI)
- Ecma International
- Electronics Industry Citizenship Coalition (EICC)
- European Information & Communications Technology Industry Association (EICTA)
- Information Technology Industry Council (ITI)
- ITI Environmental Leadership Council



Lexmark CS796de overview



Robust Colour Output. Designed for medium to large workgroups, the Lexmark CS796de meets the demands of your busy colour-printing environment. Vibrant, professional-quality output and the ability to print on a wide variety of media allow you to do more colour printing in-house. With the advanced colour laser technology of the CS796de you'll get excellent, consistent colour from the first page to the last.

- Lexmark Extra High Yield Print Cartridge available, offering yields of up to 20,000* pages
- Print speeds as fast as 50 ppm in both black and colour
- PANTONE® calibration for consistent colour tones
- Named Colour Replacement for easy colour matching
- Lexmark Colour Care Technology to manage colour usage and control costs
- Instant warm-up fuser to help reduce energy consumption and improve time to first page



Flexibility. Choose from a variety of models to best serve your needs. Select from a number of expandability options and finishing features you would expect from more expensive products.

- Ultra-reliable paper feeding to support diverse media, including card stock, labels, UV-resistant outdoor media, banner media and more
- Robust output options, including a five-bin user-assignable mailbox, an offset stacker, a staple finisher, and a staple with hole punch finisher
- Input capacity expandable to up to 3,200 sheets with the high-capacity feeder and an extra drawer
- Connectivity and application solution cards allow integration into most IT environments



Easy and Intuitive. The Lexmark CS796de is designed for easy operation and maintenance.

- 4.3-inch colour touch screen provides audible feedback to make completing tasks intuitive
- Print preview features help you select documents or specific pages within a document
- Directional lights on the device provide visual cues to guide you through tasks
- Ability to change settings such as duplex or stapling at the device
- Available device fleet management software
- Sleep Button and Hibernate Mode to reduce energy costs

*Average continuous black or composite CMY declared cartridge yield in accordance with ISO/IEC 19798.

Save time and money through solutions

Reduce unnecessary printing and simplify work processes through Lexmark solutions. The CS796de features the Lexmark Embedded Solutions Framework (eSF), our platform that enables you to add a wide range of software applications directly onto the device. Solutions are designed with your productivity in mind, helping you streamline—or even eliminate—paper intensive business processes.



Lexmark CS796de solutions

The right touch. The Lexmark e-Task colour touch screen is a key access point to your device. The customizable 4.3-inch interface gives you the ability to preview thumbnails of documents prior to printing, as well as change print jobs at the device. You can even view, select and print specific pages within a document directly from the touch screen. Its easy-to-use, intuitive navigation provides fast access to the functions and shortcuts.



The following are solutions that come preloaded on the CS796de:



Showroom

Display a customizable, scrolling slideshow on the colour touch screen to promote your business or products, or to communicate important messages to your customers or employees.



Eco-Settings

Choose from multiple print settings to help reduce energy, paper and toner consumption.



Background and Idle Screen

Change the touch screen background to your corporate logo, custom images, a unique message or select from preloaded screens.



Forms and Favorites

Eliminate waste and inefficiencies associated with preprinted forms. Store frequently printed forms, marketing materials or other documents online, then print them on demand.



Lexmark CS796de colour



Lexmark colour. Enhance comprehension and brand credibility with colour that helps your customers believe in—and remember—your products and services.

The Lexmark CS796de is perfect for printing reports, colour spreadsheets and on-demand signage with brilliant colour reproduction.

So when you put a high-quality colour document in a client's hands, you're advancing communication and your company's image at the same time. With Lexmark colour laser printing, the professionalism of your documents can finally match that of your company.



Lexmark's standard security features for your network, data and devices.

Output security has never been more important to businesses of all sizes. Lexmark's security functions include device management, device hardening and device operation. Strong multilayered security is built-in.

Device management tools include administrative access and passwords, HTTPS, SNMPv3, IP security (IPSec) and 802.1x support to remotely monitor and manage device usage.

Device hardening includes port filtering, TCP connection filtering, hard drive encryption, hard disk wiping, and digitally signed firmware updates which enhances the security of the device's network interface.

Device operation utilizes user authentication, address book lookup via LDAP over SSL and device lockout for protection of user information.

Lexmark has shown its strength and leadership with respect to security by:

- Forming and chairing the group that created the IEEE 2600 standards for security on hardcopy devices.
- Becoming the first hardcopy device manufacturer to take a holistic approach with the National Information Assurance Partnership (NIAP) Common Criteria evaluation.

Lexmark CS796de key features

Features that help you optimize your work



Lexmark CS796de colour laser printer shown with optional input drawers, finisher and caster base



1) Intuitive colour touch screen

The 4.3-inch colour touch screen allows you to operate your printer with ease and confidence through smart and intuitive navigation, easy access to workflow solutions and shortcuts, and the ability to preview your documents and print jobs at the device.



2) Flexible output options

Choose from four output options, including a five-bin mailbox, an offset stacker, a staple finisher, and a staple with hole punch finisher.



3) Direct USB

A front USB port allows for convenient walk-up preview and printing and is compatible with most printable image file formats.



4) Lexmark solutions

Reduce unnecessary printing and simplify work processes through solutions applications preloaded on your device. Choose additional Lexmark solutions to fit your unique workflow needs.



5) Expandable input

Print on multiple paper types and boost total capacity up to 3,200 sheets.



6) Long-lasting toner

The Lexmark Extra High Yield Print Cartridge delivers up to 20,000* pages, reducing interventions, cartridge waste and cost.



7) Eco-friendly features

Easy-to-access features make it easy to print responsibly, including Eco-Mode to reduce paper and toner consumption, and the Sleep Button to help you save energy.

*Average continuous black or composite CMY declared cartridge yield in accordance with ISO/IEC 19798.

Lexmark CS796de ordering information

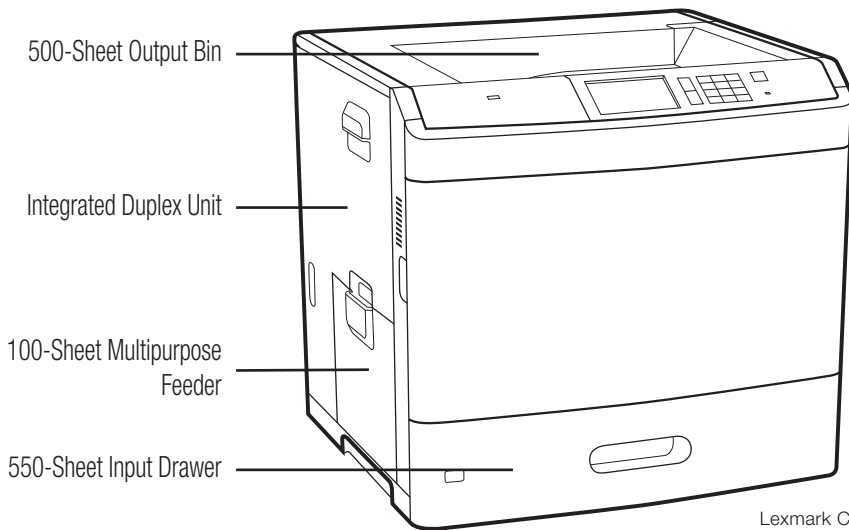

Lexmark CS796de shown
Part #47B0005

500-Sheet
Offset Stacker

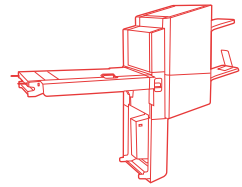

or

500-Sheet
Stapler Finisher

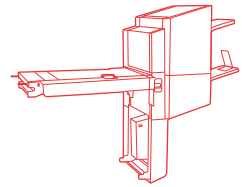

or

5-Bin Mailbox

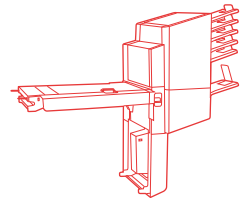

or

500-Sheet Staple
Punch Finisher

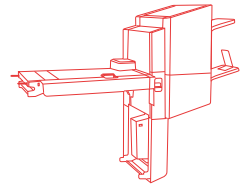

550-Sheet
Input Drawers

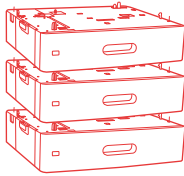

or

550-Sheet
Input Drawer
2,000-Sheet High
Capacity Feeder

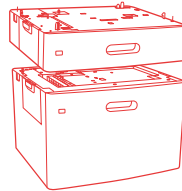

Spacers

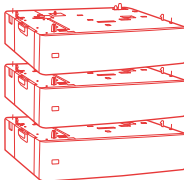

or

Caster Base
(Required for
floor standing
configuration)

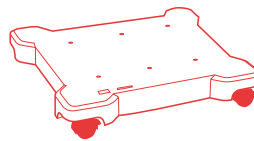

Standard

Optional

Compatible on the CS796de colour laser printer

Part # Laser Toner/Print Cartridge

24B4495	CS796 Black Extra High Yield Return Program Print Cartridge
24B4492	CS796 Magenta Extra High Yield Return Program Print Cartridge
24B4491	CS796 Cyan Extra High Yield Return Program Print Cartridge
24B4493	CS796 Yellow Extra High Yield Return Program Print Cartridge

Part # Memory Options

1025041	256MB DDR2-DRAM
1025042	512MB DDR2-DRAM
1025043	1024MB DDR2-DRAM
14F0245	256MB Flash Card
27X0014	160+GB Hard Disk

Part # Application Solutions

47B1114	Card for IPDS
47B1113	Forms and Bar Code Card
47B1115	Card for PRESCRIBE Emulation

Part # Connectivity

27X0025	MarkNet N8250 802.11b/g/n Wireless Print Server
14F0037	MarkNet N8120 Gigabit Ethernet Print Server
14F0042	MarkNet N8130 Fiber Ethernet 100BaseFX, 10BaseFL Print Server
14T0220	MarkNet™ N7020e Gigabit Ethernet Print Server
1021294	USB Cable (2-meter)
14F0000	Parallel 1284-B Interface Card
1021231	Parallel Cable (10-foot)
14F0100	RS-232C Serial Interface Card

Part # Paper Handling

47B0110	550-Sheet Input Drawer
47B0111	2,000-Sheet High Capacity Feeder
47B0112	Spacer
47B0114	Caster Base
47B1100	500-Sheet Stapler Finisher
47B1101	5-Bin Mailbox
47B1102	500-Sheet Offset Stacker
47B1103	500-Sheet Staple Punch Finisher

Lexmark CS796de product specifications



Lexmark CS796de
part # 47B0005

Speeds	
Black and Colour	Print up to 50 ppm Letter
Paper Handling	
Paper Capacity	Standard Input: 650; Standard Output: 500 Maximum Input: 3,200 (2,000 + 550 + 550 + 100); Maximum Output: 1,000
Media Information	Types: Card Stock, Dual Web Labels, Envelopes, Glossy Paper, Integrated Labels, Paper Labels, Plain Paper, Polyester Labels, Transparencies, Vinyl Labels, UV-Resistant Outdoor Media, Banner Media Size: Letter, Legal, Statement, Universal, Folio, Executive, A4, A5, JIS-B5, Envelopes (7-3/4, 9, 10, DL, B5, C5)
Print	
	Touch Screen: 4.3-inch Colour, Customizable Memory (Min/Max): 512 MB/1536 MB Time to First Page: As Fast as 8 Seconds (Black); As Fast as 8.5 Seconds (Colour) Resolution: 1200 x 1200 dpi; 4800 Colour Quality Processor: 1.2 GHz Connectivity (Standard): USB 2.0 Specification Hi-Speed Certified (Type B), Front USB 2.0 Specification Hi-Speed Certified Port (Type A), Rear USB 2.0 Specification Hi-Speed Certified Port (Type A), Ethernet 10/100/1000 BaseTX (RJ-45) Connectivity (Optional): Parallel, Serial, Wireless
Security	
	User authentication and authorization controls including LDAP; Card reader option to add an extra layer of security; Hard disk encryption protects sensitive data on the disk drive; Automatic scheduled or manual disk wiping; IPSec, SNMPv3 and 802.1x network security supported; Security-audit logging to help track and identify security risks
Supplies Yield	
	Ships with 11,000*-page Black Print Cartridge and 8,500*-Page (CMY) Print Cartridges; Aftermarket 20,000*-Page (CMYK) Extra High Yield Print Cartridges *Average continuous black or continuous composite CMY declared cartridge yield up to this number of standard pages in accordance with ISO/IEC 19798.
Recommended Monthly Volume	
	Up to 15,000 Pages/Month
	Contact your dealer about workflow solutions.

Recommended Monthly Page Volume

Recommended Monthly Page Volume is a range of pages that helps customers evaluate Lexmark's product offerings based on the average number of pages customers plan to print on the device each month. Lexmark recommends that the number of pages per month be within the stated range for optimum device performance, based on factors including: supplies replacement intervals, paper loading intervals, speed, and typical customer usage.

Trademarks

Lexmark and Lexmark with the diamond design are trademarks of Lexmark International, Inc., registered in the United States and/or other countries. All other trademarks are the property of their respective owners. PCL is a registered trademark of Hewlett-Packard Company. AppleTalk, Mac and Macintosh are trademarks of Apple Computer, Inc., registered in the United States and other countries. MarkNet and MarkVision are trademarks of Lexmark International, Inc., registered in the United States and/or other countries. ENERGY STAR® is a U.S. registered mark. Microsoft, Windows, the Windows logo, Windows Vista, and the Windows Vista logo are trademarks or registered trademarks of Microsoft Corporation in the United States and/or other countries. Citrix, MetaFrame and MetaFrame XP are registered trademarks or trademarks of Citrix Systems, Inc. in the U.S. and other countries. Information in this document is subject to change without notice.