

Lexmark XS790 Series Colour laser MFP



Work smart. Colour smart.



Colour



10.2-Inch
(25.9-cm)
Touch Screen



Copy



Scan



Fax



Solutions



Up to
50 ppm



Duplex



Network

LEXMARK
TM



Why Lexmark?

Founded in 1991 from an IBM heritage in Lexington, Kentucky, Lexmark is one of the few American companies to own, develop and market inkjet, monochrome laser and colour laser print technologies. Lexmark is poised to deliver on its promise to produce quality, dependable products well into the future.

Lexmark XS790 Series Highlights



Make a lasting impression with award-winning colour.

The documents you print define an important image - yours. That's why Lexmark colour MFPs help businesses be more productive and stand out with vibrant colour. With the ability to print professional-quality colour in-house, you can add instant impact and save costs by virtually eliminating the need to outsource print jobs. Lexmark also offers a host of colour-access and control tools to manage costs.



Eco-responsible. Printing responsibly means everyone wins – your business, your budget and the environment. Lexmark's award-winning products are designed for ease of use, high-quality output and reliable performance, with innovative capabilities that help you minimize the number of cartridges you use over the life of the printer and conserve paper and energy. Our goal is to design, package and deliver innovative products and solutions in an environmentally responsible manner.

The Lexmark Cartridge Collection Program is active around the world, providing a variety of methods for free returns of your empty cartridges to Lexmark or our collection partners. Our goal: Make it easy to do the right thing.



Environmental protection is a shared responsibility.

Through work with industry groups, Lexmark helps guide the formation of standards and guiding principles for environmental sustainability.

Our memberships include

- AeA Europe
- American National Standards Institute (ANSI)
- Ecma International
- Electronics Industry Citizenship Coalition (EICC)
- European Information & Communications Technology Industry Association (EICTA)
- Information Technology Industry Council (ITI)
- ITI Environmental Leadership Council



Lexmark XS790 Series Overview



Robust colour output. Designed for busy colour environments, the Lexmark XS790 Series delivers vibrant, professional quality output that is consistent from the first page to the last.

- Lexmark Extra High Yield Print Cartridges are available, offering yields of up to 20,000¹ pages
- Print and copy at speeds as fast as 50 ppm in both black and colour
- PANTONE® calibration for consistent colour tones
- Named Colour Replacement for easy colour matching
- Lexmark ColorCare Technology to manage colour usage and control costs
- Instant warm-up fuser to help reduce energy consumption and improve time to first page



Business productivity. The Lexmark XS790 Series combines exceptional multifunction performance with time-saving applications designed to make you more productive. These MFPs can deliver the performance of much larger copiers, but with a smaller footprint and a more affordable price.

- Duplex scanning to scan both sides of your documents in one pass
- Advanced copy functions let you interrupt long print runs to make a quick copy and proof the first copy set before completing your copy job
- Scan to multiple destinations, including scan to email, scan to FTP, scan to fax, scan to network, and more
- Preloaded applications to drive greater efficiency, and Lexmark Embedded Solutions Framework to further extend the capabilities of the device



Easy and intuitive. The Lexmark XS790 Series is designed for easy operation and maintenance.

- Extra large, easy to navigate 10.2-inch (25.9-cm) colour touch screen provides audible and tactile feedback to make completing tasks intuitive
- Print and scan preview features help you select documents or specific pages within a document
- Directional lights on the device provide visual cues to guide you through tasks
- Eco-friendly settings such as the Sleep Button and Hibernate Mode
- Available device fleet management software

Save time and money through solutions

Reduce unnecessary printing and simplify work processes through Lexmark solutions. The Lexmark XS790 Series features the Lexmark Embedded Solutions Framework (eSF), our platform that enables you to add a wide range of software applications directly onto the device. Solutions are designed with your productivity in mind, helping you streamline—or even eliminate—paper intensive business processes.

Lexmark XS790 Series Solutions

The right touch. The Lexmark e-Task colour touch screen is a key access point to your device. The extra large, customizable, 10.2-inch (25.9-cm) interface gives you the ability to preview thumbnails of documents prior to printing, as well as change print jobs at the device. You can even view, select and print specific pages within a document directly from the touch screen. Its easy-to-use, intuitive navigation provides fast access to the functions and shortcuts.



The following Lexmark solutions are just a few of those available through your authorised Lexmark Business Solutions Dealers.



Showroom

Display a customizable, scrolling slideshow on the colour touch screen to promote your business or products or to communicate important messages to your customers or employees.



Card Copy

Save time and effort in copying identification cards, licenses and insurance cards by automatically scanning, enlarging and copying both side of a two-sided card onto one side of a sheet of paper.



Background and Idle Screen

Change the touch screen background to your corporate logo, custom images or a unique message or select from preloaded screens.

The following are solutions that come preloaded on the XS790 Series MFPs.



Forms and Favourites

Eliminate waste and inefficiencies associated with preprinted forms. Store frequently printed forms, marketing materials or other documents online, then print them on demand.



Scan to Network

Scan a hard copy document and route the image to one of 30 predefined or public shared network folders.



Lexmark XS790 Series Vertical solutions



Clinical Assistant Solution for the healthcare industry designed to save clinicians time and improve patient care by streamlining common healthcare workflow processes. Consists of Scan to EMR, Physician Order Routing, Clinical Forms and Card Copy.

Education Station Solution integrated into the educational space where classroom testing and paperwork tasks can be performed with just one touch. Consists of Scan to Classroom, Print Test, Grade Test² and Forms on Demand.

Insurance Agent Solution helps an insurance company improve its common paper workflow process. Consists of Insurance Forms, Insurance Card Copy, Scan to Policy Manager, Eco Copy and Background/Idle Screen.

Contact your Lexmark Business Solutions Dealer for additional vertical solutions. Solutions are customized through dealer.

² Optional software available. Licensing fees apply.

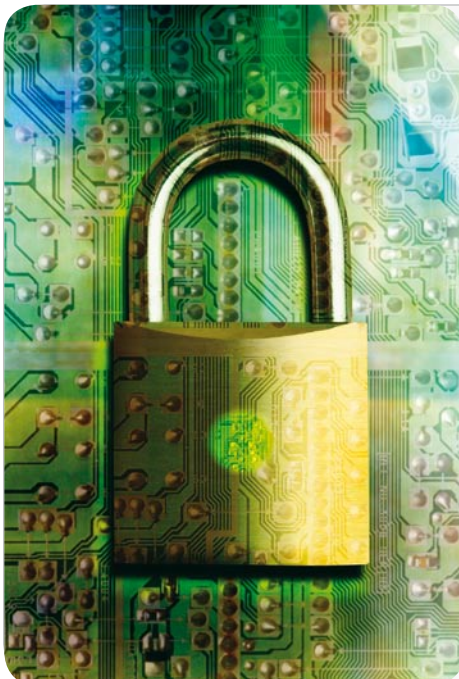

Lexmark's standard security features for your network, data and devices.

Output security has never been more important to businesses of all sizes. Lexmark's security functions include device management, device hardening and device operation. Strong multilayered security is built-in.

Device management. Tools include administrative access and passwords, HTTPS, SNMPv3, IP security (IPSec) and 802.1x support to remotely monitor and manage device usage.

Device hardening. Includes port filtering, TCP connection filtering, hard drive encryption, hard disk wiping and digitally signed firmware updates that enhance the security of the device's network interface.

Device operation. Utilizes user authentication, address book lookup via LDAP over SSL and device lockout for protection of user information.

Lexmark has shown its strength and leadership with respect to security.

- Forming and chairing the group that created the IEEE 2600 standards for security on hard copy devices.
- Becoming the first hard copy device manufacturer to take a holistic approach with the National Information Assurance Partnership (NIAP) Common Criteria evaluation.

Lexmark XS790 Series Key features

Features that help you optimize your work



1) 10.2-inch (25.9-cm) colour touch screen

Operate your device with ease through smart and intuitive navigation with audible and tactile feedback when you use the touch screen. Get easy access to workflow solutions and shortcuts and the ability to preview documents at the device.



2) Flexible output options

Choose from four output options, including a five-bin mailbox, an offset stacker, a staple finisher and a staple with hole punch finisher.



3) Single-pass automatic document feeder

Save time by scanning both sides of your document in one pass with robust colour-scanning capabilities and an input capacity of up to 75 pages.



4) Direct USB

The front USB port allows for convenient walk-up preview, printing and scanning and is compatible with most printable image file formats.

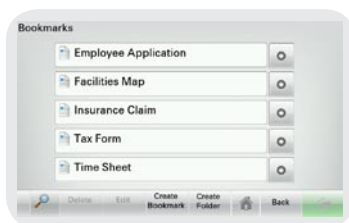

5) Lexmark solutions

Reduce unnecessary printing and simplify work processes through solutions applications preloaded on your device. Choose additional Lexmark solutions to fit your unique workflow needs.



6) Long-lasting toner

The Lexmark Extra High Yield Print Cartridge delivers up to 20,000¹ pages, reducing interventions, cartridge waste and cost.



7) Eco-friendly features

Easy-to-access features like Eco-Mode to reduce paper and toner consumption, the Sleep Button and Hibernate Mode make it easy to print responsibly and help you save energy.

Lexmark XS790 Series Ordering information

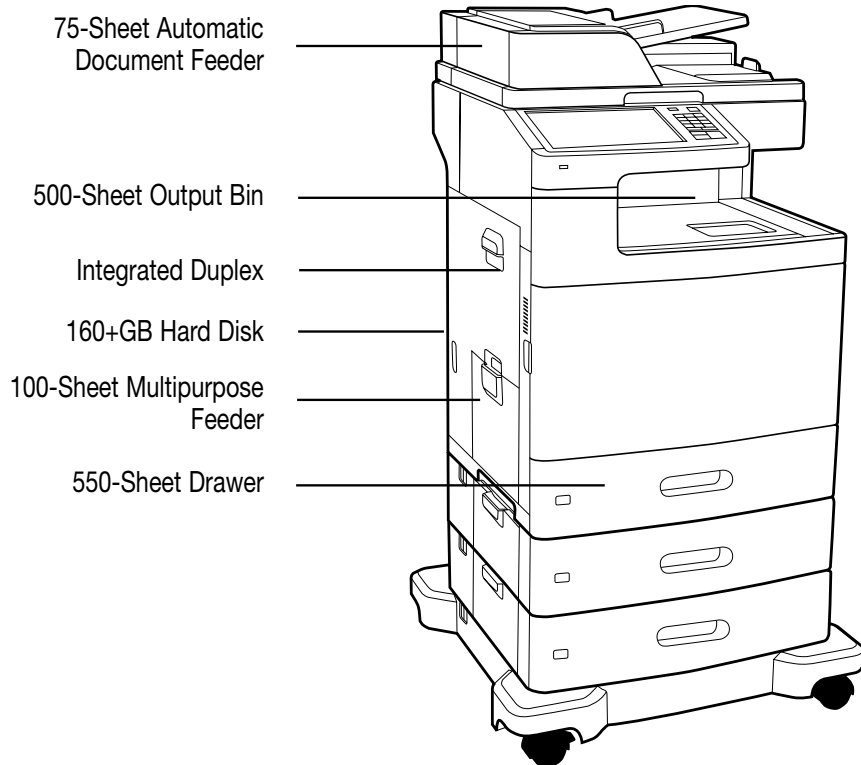

500-Sheet
Offset Stacker

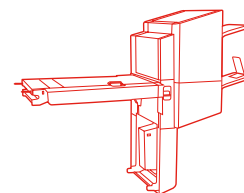

or

500-Sheet
Staple Finisher

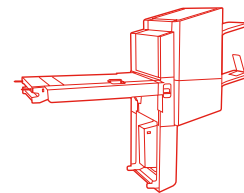

or

5-Bin Mailbox

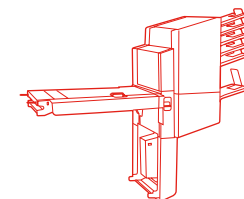

or

500-Sheet Staple
Punch Finisher

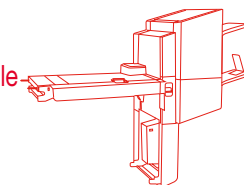

Banner Media Tray Available

550-Sheet
Drawer



or

2,000-Sheet
High-Capacity
Feeder

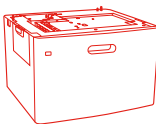

Standard
Optional

Compatible on the XS790 Series

Part #	Model
47B1287	Lexmark XS795dte
47B1290	Lexmark XS798dte
Part #	Laser Toner/Print Cartridge
24B6022	XS795, XS798 Black Extra High Yield Return Program Print Cartridge
24B6018	XS795, XS798 Cyan Extra High Yield Return Program Print Cartridge
24B6019	XS795, XS798 Magenta Extra High Yield Return Program Print Cartridge
24B6021	XS795, XS798 Yellow Extra High Yield Return Program Print Cartridge
C792X77G	C792, X792 Waste Toner Bottle
25A0013	Staple Cartridges (3 pack)
Part #	Paper Handling
47B0110	C792, X792 550-Sheet Drawer
47B1101	C792, X792 5-Bin Mailbox
47B1102	C792, X792 500-Sheet Offset Stacker
47B1100	C792, X792 500-Sheet Staple Finisher
47B1103	C792, X792 500-Sheet Staple, Hole Punch Finisher
47B0112	C792, X792 Spacer
47B0118	X792 Banner Media Tray
Part #	Memory Options
1025041	256MB DDR2-DRAM
1025042	512MB DDR2-DRAM

1025043	1024MB DDR2-DRAM
14F0245	256MB Flash Card
30G0287	Arabic Font Card
30G0828	Japanese Font Card
30G0825	Korean Font Card
30G0826	Simplified Chinese Font Card
30G0827	Traditional Chinese Font Card
Part #	Application Solutions
47B1111	X792 Card for IPDS
47B1110	X792 Forms and Bar Code Card
47B1112	X792 Card for PRESCRIBE Emulation
57X9000	Lexmark PrintCryption Card
57X0020	PKI Authentication App for eSF Capable Devices
3053996	Large Pod for PKI Card Reader
Part #	Connectivity
27X0025	MarkNet N8250 802.11b/g/n Wireless Print Server
14F0042	MarkNet N8130 Fiber Ethernet 100BaseFX, 10BaseFL Print Server
14T0220	MarkNet™ N7020e Gigabit Ethernet Print Server
1021294	USB (2 Meter) Cable
14F0000	Parallel 1284-B Interface Card
14F0100	RS-232C Serial Interface Card
Part #	User Replaceable Parts
40X7100	C792, X792 Fuser Maintenance Kit 110-120V

40X7103	C792, X792 Transfer module Maintenance Kit
40X7220	X792 ADF Maintenance Kit

Lexmark XS790 Series Product specifications



Product specifications

Lexmark XS795dte

Lexmark XS798dte

Printing	
Display	Lexmark e-Task 10.2-inch (25.9 cm) colour touch screen with audible and tactile feedback
Print Speed: Up to	Black: 37 ppm / Colour: 37 ppm
Time to First Page: As fast as	Black: 9 seconds / Colour: 10 seconds
Print Resolution, Colour	1200 x 1200 dpi, 4800 Colour Quality (2400 x 600 dpi)
Processor Speed	1.2 GHz
Memory	Standard: 1024 MB / Maximum: 2048 MB
Hard Disk	Included in configuration
Recommended Monthly Page Volume ²	2500 - 14000 pages
Maximum Monthly Duty Cycle: Up to ³	150000 pages per month
Copying	
Copy Speed: Up to	Black: 37 cpm / Colour: 37 cpm
Time to First Copy: As fast as	Black: 11.5 seconds / Colour: 13.5 seconds
Reduce / Enlarge Range	25 - 400%
Scanning	
Duplex Scan Speed: Up to	A4/Ltr, Black: 56 / 58 sides per minute - A4/Ltr, Colour: 52 / 54 sides per minute
Simplex Scan Speed: Up to	A4/Ltr, Black: 47 / 49 sides per minute - A4/Ltr, Colour: 47 / 49 sides per minute
Scanner Type	Flatbed scanner with ADF
Hardware Scanning Resolution	600 X 600 ppi
Faxing	
Modem Speed	33.6 Kbps
Supplies	
Supplies Yield	18,000 ¹ -page Colour Extra High Yield Print Cartridges (CMY), 20,000 ¹ -page Black Extra High Yield Print Cartridge
Paper Handling	
Paper Handling Standard	500-Sheet Output Bin, Integrated Duplex, 100-Sheet Multipurpose Feeder, 550-Sheet Input Tray, 2 x 550-Sheet Drawers
Paper Handling Optional	5-Bin Mailbox, 550-Sheet Drawer, Banner Media Tray, 500-Sheet Offset Stacker, 500-Sheet Staple Finisher, 500-Sheet Staple Punch Finisher
Paper Input Capacity: Up to	Standard: 1750 pages 20 lb or 75 gsm bond / Maximum: 3200pages 20 lb or 75 gsm bond (Remove 550-Sheet Drawer, add 2000-Sheet High Capacity Feeder and a finishing option)
Paper Output Capacity: Up to	Standard: 500 pages 20 lb or 75 gsm bond / Maximum: 1000 pages 20 lb or 75 gsm bond
Media Types Supported	Card Stock, Dual Web Labels, Envelopes, Glossy paper, Integrated Labels, Paper Labels, Plain Paper, Polyester Labels, Transparencies, Vinyl Labels, Refer to the Card Stock & Label Guide, Outdoor Media, Banner Paper
Media Sizes Supported	10 Envelope, 7 3/4 Envelope, 9 Envelope, A4, A5, B5 Envelope, C5 Envelope, DL Envelope, Executive, Folio, JIS-B5, Legal, Letter, Statement, Universal
General	
Standard Ports	USB 2.0 Specification Hi-Speed Certified (Type B), Front USB 2.0 Specification Hi-Speed Certified port (Type A), Rear USB 2.0 Specification Hi-Speed Certified port (Type A), Ethernet 10/100/1000 BaseTX (RJ-45)
Optional Network Ports	External MarkNet™ N7020e Gigabit Ethernet, Internal MarkNet™ N8130 Fiber Fast Ethernet, Internal MarkNet™ N8250 802.11b/g/n Wireless
Optional Local Ports	Internal RS-232C serial, Internal 1284-B Bidirectional Parallel
Noise Level, Operating	Print: 51 dBA / Copy: 52 dBA / Scan: 54 dBA
Energy Star	Yes
Specified Operating Environment	Temperature: 16 to 32°C (60 to 90°F), Humidity: 8 to 80% Relative Humidity, Altitude: 0 - 3048 Meters (10,000 Feet)
Size (in. - H x W x D) / Weight (lb.)	47.4 x 24.05 x 25.9 in. / 247 lb.

¹ Based on approximately 5% print coverage. Actual yields may vary based on factors such as page coverage, image type, job size, print/copy/fax modes, and duplexing.

² "Recommended Monthly Page Volume" is a range of pages that helps customers evaluate Lexmark's product offerings based on the average number of pages customers plan to print on the device each month. Lexmark recommends that the number of pages per month be within the stated range for optimum device performance, based on factors including: supplies replacement intervals, paper loading intervals, speed, and typical customer usage.

³ "Maximum Monthly Duty Cycle" is defined as the maximum number of pages a device could deliver in a month using a multishift operation. This metric provides a comparison of robustness in relation to other Lexmark printers and MFPs.



Lexmark and Lexmark with the diamond design are trademarks of Lexmark International, Inc., registered in the United States and/or other countries. All other trademarks are the property of their respective owners. Information in this document is subject to change without notice. PANTONE® is a registered trademark of Pantone, Inc. AirPrint and the AirPrint logo are trademarks of Apple Inc.

LEXMARK
TM